

Linear Roller Way X

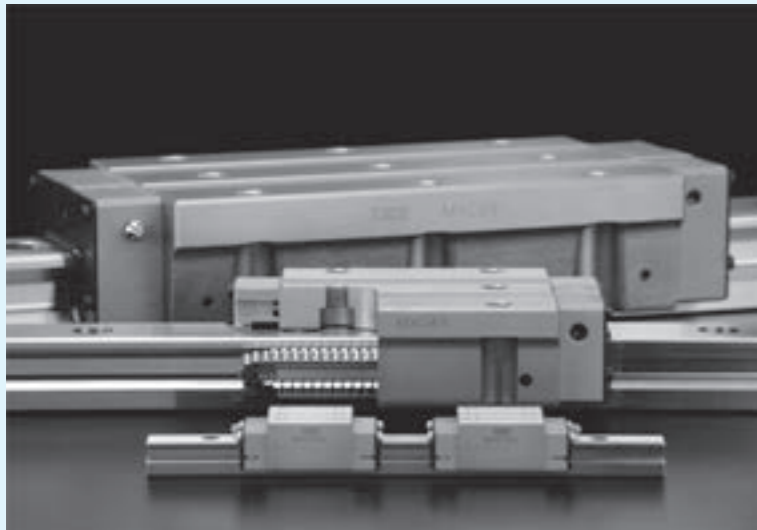

Linear Roller Way X

LRWX

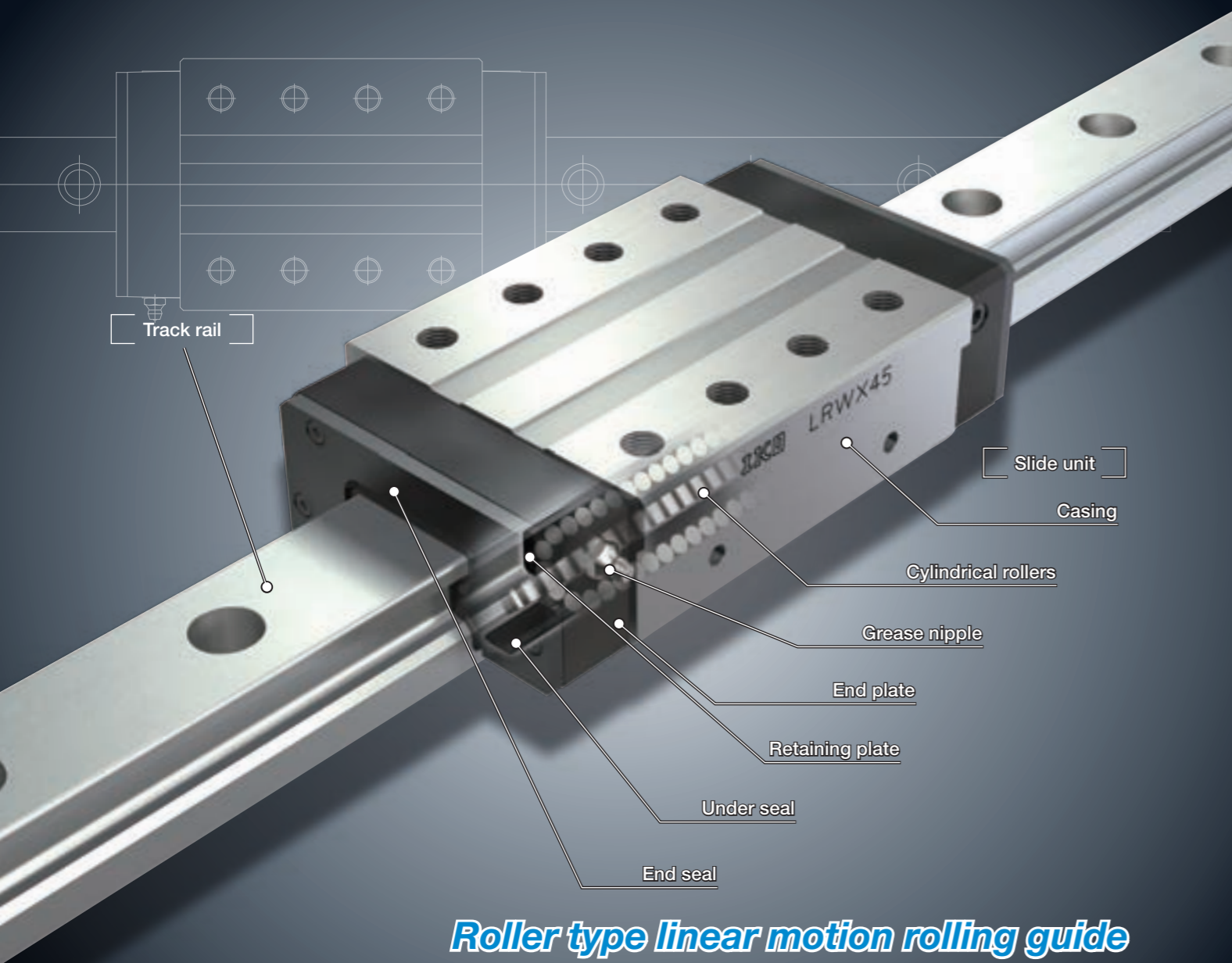
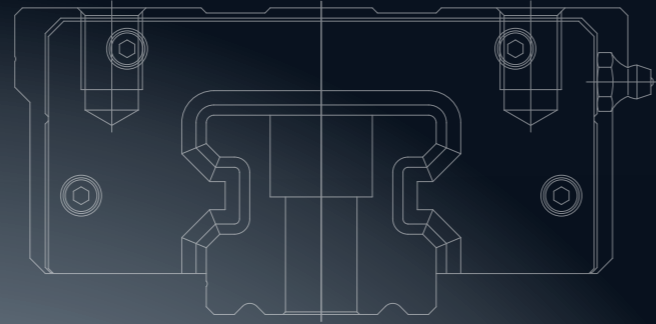

**Roller type linear motion rolling guide
with cylindrical rollers in four-rows!**

**Well-balanced roller arrangement
enabling equal resistance to all direction loads!**

**Slide unit shape block type and flange type are available
and can be selected according to the application!**

Identification Number and Specification

Example of an identification number

The specification of LRWX series is indicated by the identification number. Indicate the identification number, consisting of a model code, dimensions, a part code, a preload symbol, a classification symbol, and any supplemental codes for each specification to apply.

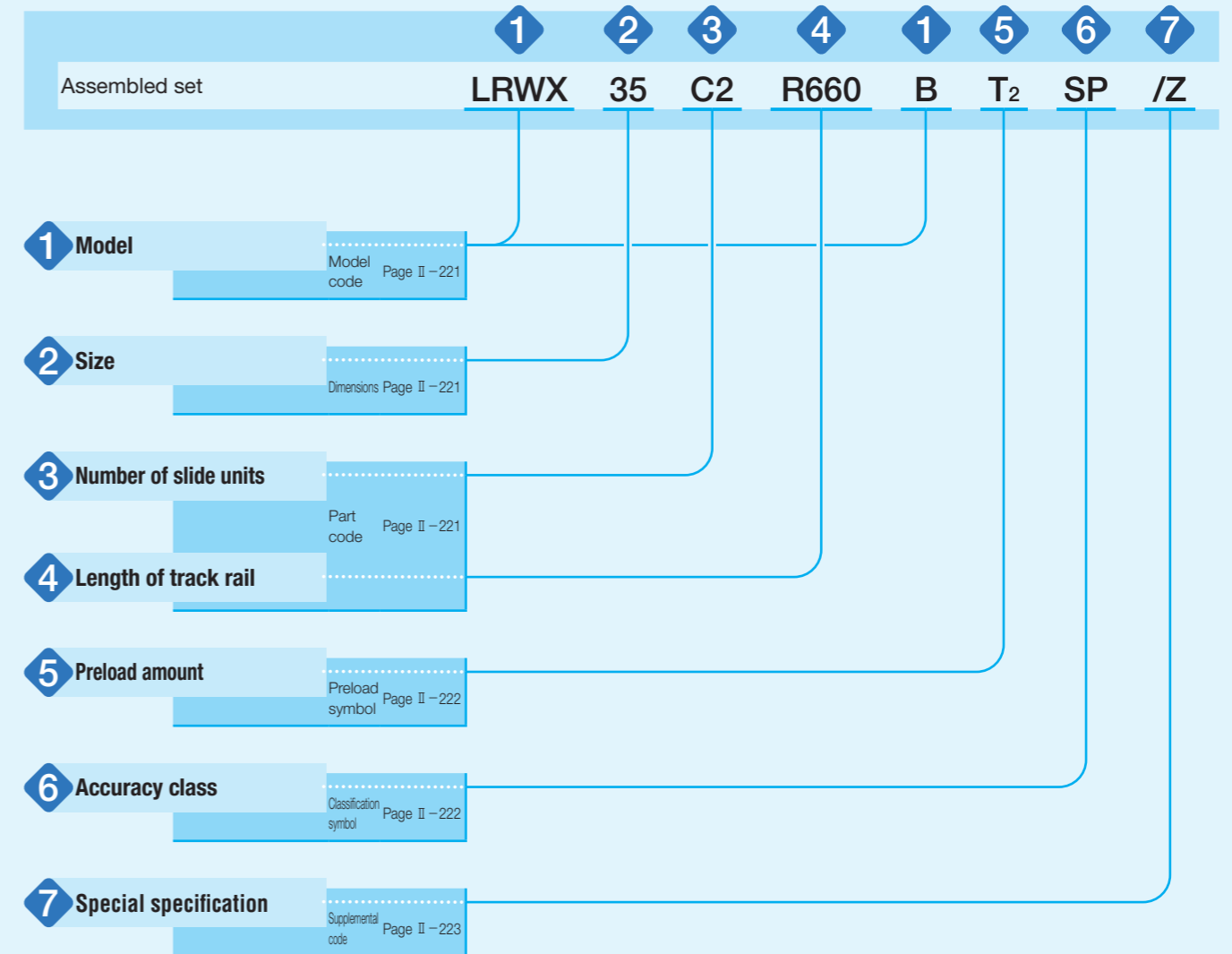

Identification Number and Specification – Model · Size · Number of Slide Unit · Length of Track Rail –

1 Model	Linear Roller Way X ⁽¹⁾ (LRWX series)	Block type mounting from top : LRWX...B Flange type mounting from bottom : LRWXH
	For applicable models and sizes, see Table 1. Note ⁽¹⁾ This model has no built-in C-Lube.	
2 Size	25,35,45,55,75	For applicable models and sizes, see Table 1.
3 Number of slide units	: C○	Indicates the number of slide units assembled on a track rail.
4 Length of track rail	: R○	Indicate the length of track rail in mm. For standard and maximum lengths, see Table 2.

Table 1 Models and sizes of LRWX series

Shape	Model	Size				
		25	35	45	55	75
Block type mounting from top 	LRWX...B	○	○	○	○	○
Flange type mounting from bottom 	LRWXH	—	○	○	○	○

Table 2 Standard and maximum lengths of track rail



Item	Identification number	LRWX25...B	LRWX25...B/HP ⁽³⁾	LRWX 35...B LRWXH35	LRWX 45...B LRWXH45	LRWX 55...B LRWXH55	LRWX 75...B LRWXH75
		Standard length L (n)		480 (8) 660 (11) 840 (14) 1 020 (17) 1 200 (20) 1 500 (25)	480 (16) 660 (22) 840 (28) 1 020 (34) 1 200 (40) 1 500 (50)	480 (8) 660 (11) 840 (14)	800 (10) 1 040 (13) 1 200 (15) 1 520 (19)
Pitch of mounting holes F		60	30	60	80	100	120
E		30	15	30	40	50	60
Standard E or higher dimensions ⁽¹⁾ below		9	9	12	15	18	23
Maximum length ⁽²⁾		1 980 (3 000)	1 980 (3 000)	3 000 (3 960)	2 960 (4 000)	3 000 (4 000)	3 000 (3 960)

Notes ⁽¹⁾ Not applicable to female threads for bellows (supplemental code "J").

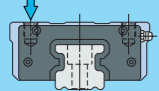
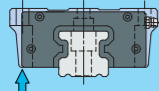
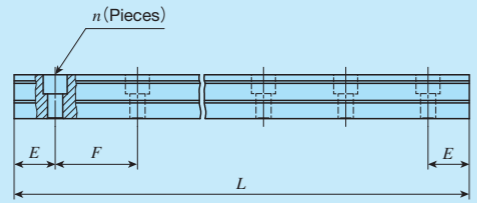
⁽²⁾ Length up to the value in () can be produced. If needed, please contact **IKO**.

⁽³⁾ This indicates the dimension for the half pitch mounting holes specification of track rail.

Remark: If not directed, E dimensions for both ends will be the same within the range of standard E dimensions. To change the dimensions, indicate the specified rail mounting hole positions "B/E" of special specification. For more information, see page III-30.

– Preload Amount · Accuracy Class –

5 Preload amount	Standard : No symbol Light preload : T ₁ Medium preload : T ₂ Heavy preload : T ₃	For details of the preload amount, see Table 3.
6 Accuracy class	High : H Precision : P Super precision : SP Ultra precision : UP	For details of accuracy class, see Table 4.

Table 3 Preload amount

Preload type	Item	Preload symbol	Preload amount N	Operational conditions
Standard	(No symbol)		0 ⁽¹⁾	· Light and precise motion
Light preload	T ₁		0.02 C ₀	· Almost no vibrations · Load is evenly balanced · Light and precise motion
Medium preload	T ₂		0.05 C ₀	· Medium vibration · Medium overhung load
Heavy preload	T ₃		0.08 C ₀	· Operation with vibration and / or shock · Overhanging load applied · Heavy cutting

Note ⁽¹⁾ Indicates zero or minimal amount of preload.

Remark: C₀ indicates the basic static load rating.

Table 4 Tolerance and allowance

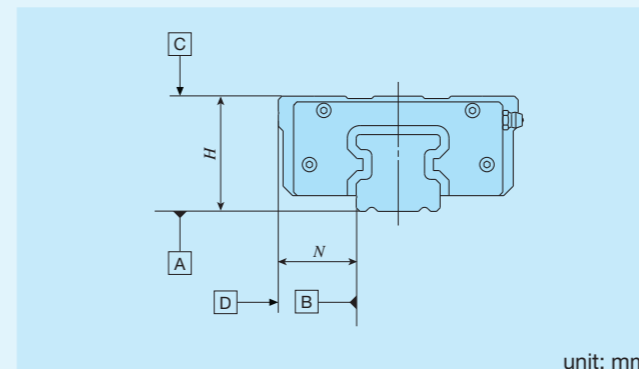

Item	Class (classification symbol)			
	High (H)	Precision (P)	Super precision (SP)	Ultra precision (UP)
Dim. H tolerance	±0.040	±0.020	±0.010	±0.008
Dim. N tolerance	±0.050	±0.025	±0.015	±0.010
Dim. variation of H ⁽¹⁾	0.015	0.007	0.005	0.003
Dim. variation of N ⁽¹⁾	0.020	0.010	0.007	0.003
Dim. variation of H for multiple assembled sets	0.035	0.025	—	—
Parallelism in operation of the slide unit C surface to A surface	See Fig. 1			
Parallelism in operation of the slide unit D surface to B surface	See Fig. 1			

Note ⁽¹⁾ It means the size variation between slide units mounted on the same track rail.

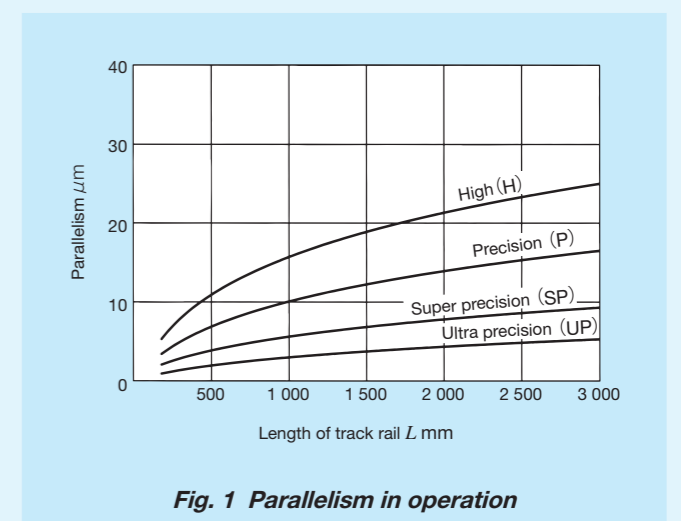

7 Special specification

/A, /D, /E, /F, /HP, /I, /JO, /LO, /LFO, /Q, /VO, /WO, /YO, /ZO

For applicable special specifications, see Table 5.
For combination of multiple special specifications, see Table 6.
For details of special specifications, see page III-29.

Table 5 Application of special specifications

Special specification	Supplemental code	Size				
		25	35	45	55	75
Butt-jointing track rails	/A	○	○	○	○	○
Opposite reference surfaces arrangement	/D	○	○	○	○	○
Specified rail mounting hole positions	/E	○	○	○	○	○
Caps for rail mounting holes	/F	○	○	○	○	○
Half pitch mounting holes for track rail	/HP	○	×	×	×	×
Inspection sheet	/I	○	○	○	○	○
Female threads for bellows	/JO	○	○	○	○	○
Black chrome surface treatment	/LO	○	○	○	○	○
Fluorine black chrome surface treatment	/LFO	○	○	○	○	○
With C-Lube plate	/Q	○	○	○	○	○
Double seals	/VO	○	×	×	×	×
A group of multiple assembled sets	/WO	○	○	○	○	○
Specified grease	/YO	○	○	○	○	○
Scrapers	/ZO	○	○	○	○	○

Table 6 Combination of supplemental codes

D	○													
E	-	-												
F	○	○	○											
HP	-	○	-	○										
I	○	○	○	○	○									
J	○	○	○	○	○	-	○							
L	○	○	○	○	○	○	○	○						
LF	○	○	○	○	○	○	○	○	-					
Q	○	○	○	○	○	○	-	○	○					
V	○	○	○	○	○	○	○	○	○	-				
W	○	○	-	○	○	○	○	○	○	○	○			
Y	○	○	○	○	○	○	○	○	○	-	○	○		
Z	○	○	○	○	○	○	-	○	○	○	-	○	○	
A	D	E	F	HP	I	J	L	LF	Q	V	W	Y		

Remarks 1. The combination of "-" shown in the table is not available.

2. When using multiple types for combination, please indicate by arranging the symbols in alphabetical order.

Table 7 Dimension of female threads for bellows (Supplemental code: /J /JJ)

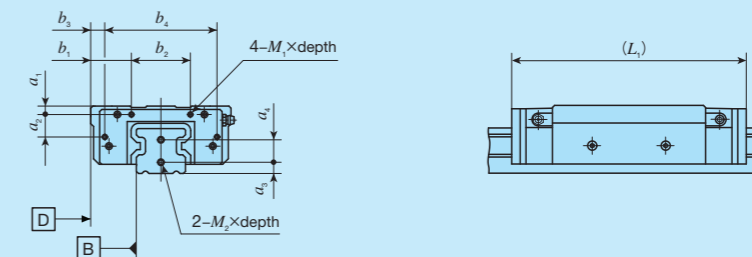

unit: mm

Identification number	Slide unit								Track rail		
	a_1	a_2	b_1	b_2	b_3	b_4	$M_1 \times \text{depth}$	$L_1^{(1)}$	a_3	a_4	$M_2 \times \text{depth}$
LRWX 25...B	5	12	15	33	7	49	M3×6	116	7	12	M4×8
LRWX 35...B	6	16	29	42	10	80	M3×6	166	8	16	M4×8
LRWXH 35			31		12						
LRWX 45...B	8	20	34	52	12	96	M4×8	221	10	19	M5×10
LRWXH 45			38		16						
LRWX 55...B	9	24	36	68	15	110	M5×10	282	12	23	M6×12
LRWXH 55			43		22						
LRWX 75...B	10	35	35	110	15.5	149	M5×10	366	15	30	M6×12
LRWXH 75			42		22.5						

Note (1) Dimensions of the specification that female threads for bellows are fitted to both ends of the slide unit are indicated.

Table 8 Dimension of slide unit with C-Lube plate (Supplemental code /Q)

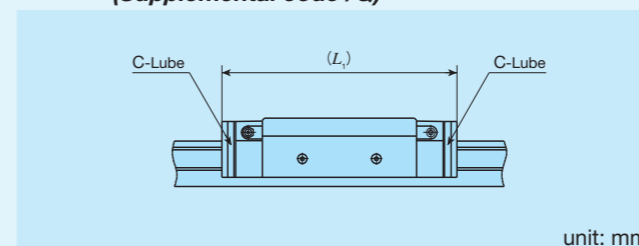

unit: mm

Size	L_1
25	120
35	166
45	218
55	275
75	364

Remark: The dimensions of the slide unit with C-Lube at both ends are indicated.

Table 9 Dimension of slide unit with scrapers (Supplemental code: /Z /ZZ)

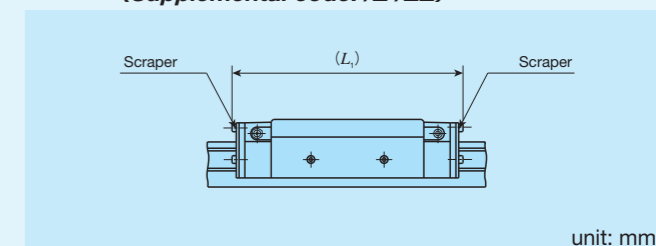

unit: mm

Size	L_1
25	120
35	164
45	217
55	275
75	361

Remark: The dimensions of the slide unit with scraper at both ends are indicated.

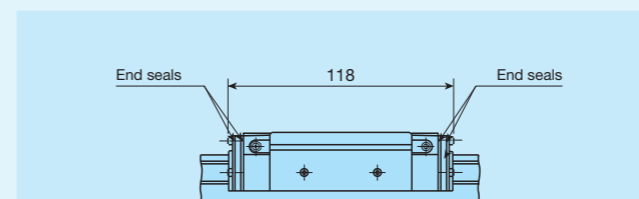

Fig. 2 Dimensions of slide unit with double seals (Size 25) (Supplemental code: /V /VV)

Remark: The dimensions of the slide unit with double end seals at both ends are indicated.

Lubrication

Lithium-soap base grease with extreme-pressure additive (Alvania EP Grease 2 [SHOWA SHELL SEKIYU K. K.]) is pre-packed in LRWX series. LRWX series has grease nipple as indicated in Table 10.

Table 10 Parts for lubrication

Size	Grease nipple type (1)	Applicable supply nozzle type	Bolt size of female threads for piping
25	JIS type 1	Grease gun available on the market	M6
35			
45	JIS type 2		PT1/8
55			
75			

Note (1) For grease nipple specification, see Table 14.2 on page III-23.
Remark: Stainless steel grease nipple is also available. If needed, please contact **IKO**.

Dust Protection

The slide units of LRWX series are equipped with end seals and under seals as standard for dust protection. However, if large amount of contaminant or dust are floating, or if large particles of foreign substances such as chips or sand may adhere to the track rail, it is recommended to cover the whole unit with bellows or telescope type shield, etc. LRWX series is provided with specific bellows. The bellows are easy to mount and provide excellent dust protection. If

needed, please refer to III-26 for ordering.

Precaution for Use

1 Mounting surface, reference mounting surface and typical mounting structure

When mounting the LRWX series, properly align the reference mounting surfaces B and D of the track rail and slide unit with the reference mounting surface of the table and bed and fix them. (See Fig. 3)

Reference mounting surfaces B and D and mounting surfaces A and C are ground precisely. Machining the mounting surface of the table and bed, such as machine or device, to high accuracy and mounting them properly will ensure stable linear motion with high accuracy.

Reference mounting surface of the slide unit is the opposite side of the **IKO** mark. The track rail reference mounting surface is identified by locating the **IKO** mark on the top surface of the track rail. It is the side surface above the mark (in the direction of the arrow). (See Fig. 4)

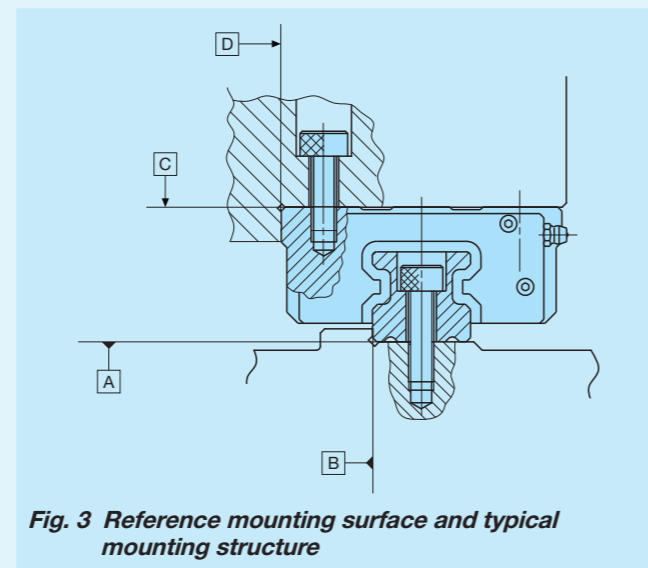

Fig. 3 Reference mounting surface and typical mounting structure

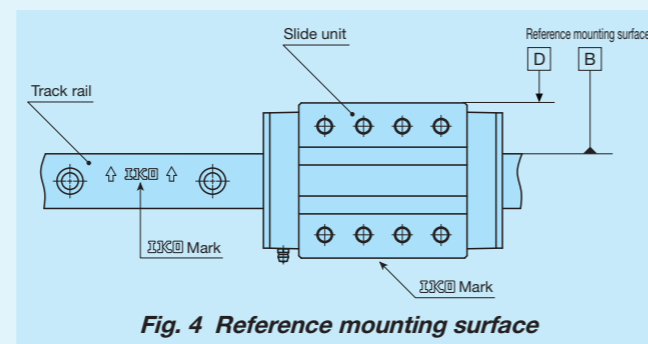

Fig. 4 Reference mounting surface

2 Fixing the slide unit

Slide unit of LRWX25... B and LRWXH is also provided with mounting holes in the middle of width direction (see Fig. 5) and has the arrangement to receive the applied load in a good balance. When designing machines or equipment, consider the arrangement so that the mounting holes in the middle of slide unit can also be used to fix the units, to use the highest performance out of the product.

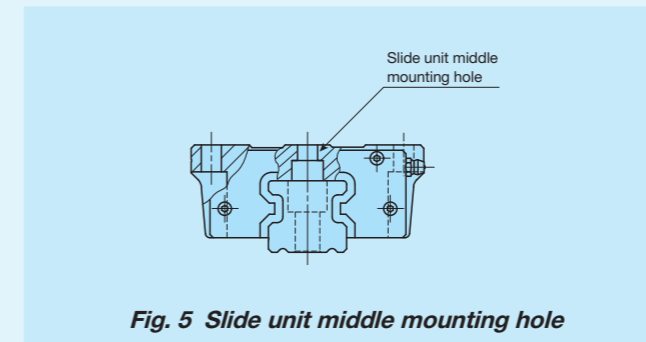

Fig. 5 Slide unit middle mounting hole

3 Shoulder height and corner radius of the reference mounting surface

For the opposite corner of the mating reference mounting, it is recommended to have relieved fillet as indicated in Fig. 6, but you may also use it with providing corner radius R as shown in Table 11. Recommended value for the shoulder height and corner radius on the mating side is indicated in Table 11.

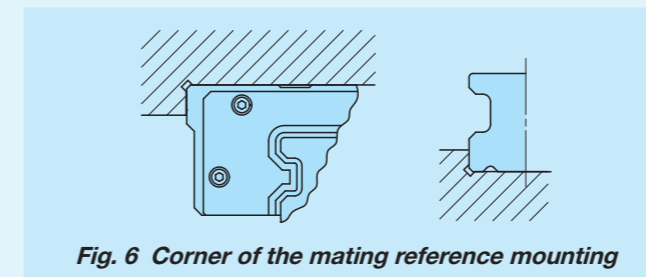

Fig. 6 Corner of the mating reference mounting

Table 11 Shoulder height and corner radius of the reference mounting surface

Size	Shoulder height of slide unit mounting part	Shoulder height of track rail mounting part	Corner radius
	h_1	h_2	R (Maximum)
25	6	4	1
35	8	5.5	1
45	8	6	1
55	10	8	1.5
75	10	8	1.5

unit: mm

4 Tightening torque for fixing screw

Typical tightening torque for mounting of the LRWX series to the steel mating member material is indicated in Table 12. When vibration and shock of the machine or device are large, fluctuating load is large, or moment load is applied, fix it by using the torque 1.2 to 1.5 times larger than the value indicated in the table as necessary. If the mating member material is cast iron or aluminum alloy, reduce the tightening torque depending on the strength characteristics of the mating member material.

Table 12 Tightening torque for fixing screw

Bolt size	Tightening torque N · m
	High carbon steel-made screw
M 6×1	13.6
M 8×1.25	32.7
M10×1.5	63.9
M12×1.75	110
M16×2	268
M24×3	749

Remark: The tightening torque is calculated based on strength division 12.9 for product size up to 55, and strength division 10.9 for product size 75.

IKO Linear Roller Way X

Block type mounting from top

Shape	LRWX...B				
Size	25	35	45	55	75

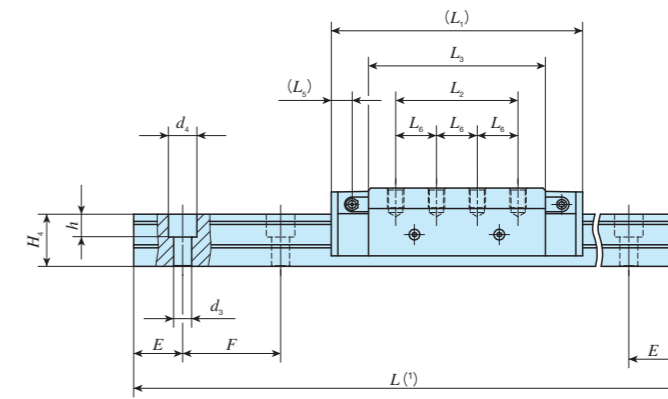
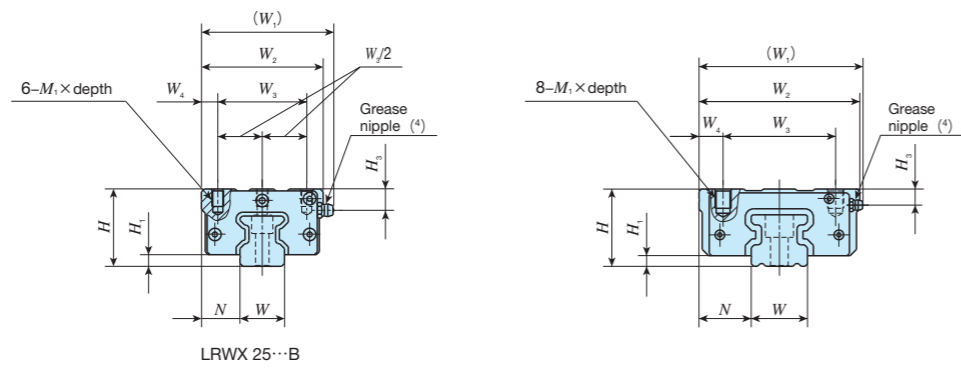

Identification number	Mass (Ref.)		Dimensions of assembly mm			Dimensions of slide unit mm										Dimensions of track rail mm						Appended mounting bolt for track rail ⁽²⁾	Basic dynamic load rating ⁽³⁾	Basic static load rating ⁽³⁾	Static moment rating ⁽³⁾				
	Slide unit kg	Track rail kg/m	H	H ₁	N	W ₁	W ₂	W ₃	W ₄	L ₁	L ₂	L ₃	L ₅	L ₆	M ₁ × depth	H ₃	W	H ₄	d ₃	d ₄	h				E	F	Bolt size × ℓ	C	C ₀
LRWX 25...B	0.93	3.70	40	6	20	69	63	46	8.5	109	45	74.4	11	—	M 6 × 9	11	23	26	7	11	9	30	60	M 6 × 28	32 700	70 300	1 110	885 5 170	885 5 170
LRWX 35...B	2.65	6.66	48	6.5	32.5	103	100	70	15	154	75	108.4	12.8	25	M10 × 12	10	35	32	11	17.5	14	30	60	M10 × 35	49 900	91 100	2 150	1 660 9 450	1 660 9 450
LRWX 45...B	5.32	10.3	60	8	37.5	125	120	82	19	205	105	144	18.5	35	M12 × 16	14.5	45	39	14	20	16	40	80	M12 × 40	93 300	167 000	5 000	4 030 23 000	4 030 23 000
LRWX 55...B	9.09	15.3	70	9	42.5	142	140	95	22.5	262	135	189	24.5	45	M12 × 18	16	55	47	18	26	21	50	100	M16 × 50	186 000	330 000	12 200	10 700 57 900	10 700 57 900
LRWX 75...B	19.0	25.1	90	10	52.5	190	180	123	28.5	346	180	240	45	60	M16 × 25	20	75	57	26	39	30	60	120	M24 × 60	298 000	518 000	25 200	20 900 121 000	20 900 121 000

- Notes ⁽¹⁾ Track rail lengths *L* are shown in Table 2 on page II-221.
⁽²⁾ The appended track rail mounting bolts are hexagon socket head bolts equivalent to JIS B 1176.
⁽³⁾ The direction of basic dynamic load rating (*C*), basic static load rating (*C₀*), and static moment rating (*T₀*, *T_x*, *T_y*) are shown in the sketches below. The upper values of *T_x* and *T_y* are for one slide unit and the lower values are for two slide units in close contact.
⁽⁴⁾ The shapes of grease nipple vary by size. The specifications are shown in Table 10 on page II-225.

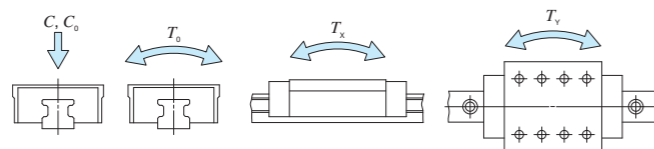

Example of identification number of assembled set

Model code	Dimensions	Part code	Model code	Preload symbol	Classification symbol	Supplemental code
LRWX	35	C2	R840	B	T ₁	P /W2
①	②	③	④	⑤	⑥	⑦
① Model LRWX...B Block type mounting from top	② Size 25, 35, 45, 55, 75	③ Number of slide unit (2)	④ Length of track rail (840 mm)	⑤ Preload amount No symbol Standard T ₁ Light preload T ₂ Medium preload T ₃ Heavy preload	⑥ Accuracy class H High P Precision SP Super precision UP Ultra precision	⑦ Special specification A, D, E, F, HP, I, J L, LF, O, V, W, Y, Z

Flange type mounting from bottom

Shape	LRWXH			
Size	35	45	55	75

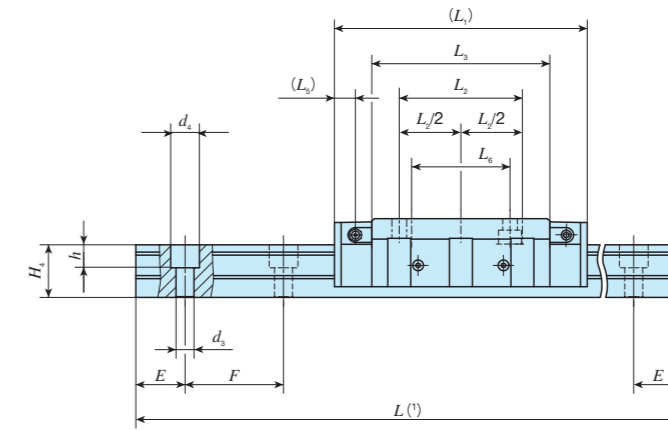
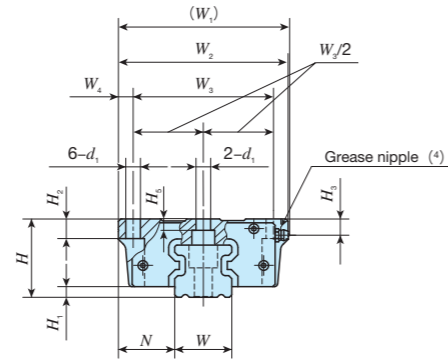

Identification number	Mass (Ref.)		Dimensions of assembly mm			Dimensions of slide unit mm											Dimensions of track rail mm						Appended mounting bolt for track rail (2) Bolt size × ℓ	Basic dynamic load rating (3) C N	Basic static load rating (3) C ₀ N	Static moment rating (3)					
	Slide unit kg	Track rail kg/m	H	H ₁	N	W ₁	W ₂	W ₃	W ₄	L ₁	L ₂	L ₃	L ₅	L ₆	d ₁	H ₂	H ₃	H ₅	W	H ₄	d ₃	d ₄				h	E	F	T ₀ N · m	T _x N · m	T _y N · m
LRWXH 35	2.51	6.66	48	6.5	34.5	105	104	86	9	154	75	108.4	12.8	60	9	12	10	7	35	32	11	17.5	14	30	60	M10×35	49 900	91 100	2 150	1 660 9 450	1 660 9 450
LRWXH 45	5.18	10.3	60	8	41.5	129	128	108	10	205	105	144	18.5	80	11	15	14.5	10	45	39	14	20	16	40	80	M12×40	93 300	167 000	5 000	4 030 23 000	4 030 23 000
LRWXH 55	9.08	15.3	70	9	49.5	—	154	130	12	262	135	189	24.5	106	14	18	16	10	55	47	18	26	21	50	100	M16×50	186 000	330 000	12 200	10 700 57 900	10 700 57 900
LRWXH 75	19.7	25.1	90	10	59.5	197	194	164	15	346	180	240	45	134	18	24	20	16	75	57	26	39	30	60	120	M24×60	298 000	518 000	25 200	20 900 121 000	20 900 121 000

Notes (1) Track rail lengths L are shown in Table 2 on page II - 221.

(2) The appended track rail mounting bolts are hexagon socket head bolts equivalent to JIS B 1176.

(3) The direction of basic dynamic load rating (C), basic static load rating (C_0), and static moment rating (T_0 , T_x , T_y) are shown in the sketches below. The upper values of T_x and T_y are for one slide unit and the lower values are for two slide units in close contact.

(4) The shapes of grease nipple vary by size. The specifications are shown in Table 10 on page II - 225.

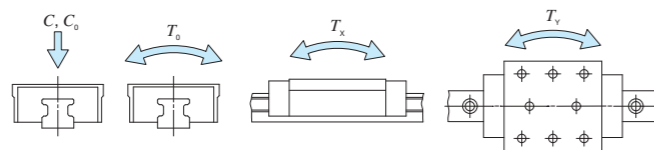

Example of identification number of assembled set

Model code: LRWXH Dimensions: 35 Part code: C2 Preload symbol: R840 Classification symbol: T1 Supplemental code: P /W2

① Model
LRWXH Flange type mounting from bottom

② Size
35, 45, 55, 75

③ Number of slide unit (2)

④ Length of track rail (840 mm)

⑤ Preload amount
No symbol Standard
T1 Light preload
T2 Medium preload
T3 Heavy preload

⑥ Accuracy class
H High
P Precision
SP Super precision
UP Ultra precision

⑦ Special specification
A, D, E, F, HP, I, J
L, LF, O, V, W, Y, Z