



Stehlagergehäuse Reihe GOS/GOF für Ölschmierung (A)

GOS/GOF Stehlagergehäuse sind für Lagerfälle vorgesehen, bei denen hohe Drehzahlen und/oder hohe Temperaturen anfallen. Diese Gehäuse sind mit Ölförderring-Schmierung ausgerüstet und werden überwiegend im Ventilatorenbereich eingesetzt.

GOS/GOF-Stehlagergehäuse werden aus Werkstoff GG 25 hergestellt. Bei Bedarf sind diese Gehäuse jedoch auch in GGG 40 oder GS 45 lieferbar. Der Ölförderring wird aus Stahl hergestellt.

Die Abdichtung der Gehäuse wird durch Labyrinthringe gewährleistet. Bei Endlagern (Ausführung A) wird einseitig die Labyrinthabdichtung durch einen geschlossenen Gussabschlussdeckel ersetzt.

Wahlweise sind die Gehäuse als Fest- und Loslager ausgelegt.

Entlüftungsventile und Ölstandsanzeiger gehören zum Lieferumfang.

Die Gehäusetypen GOS und GOF unterscheiden sich lediglich durch verschiedene Einbaumaße und unterschiedliche Konstruktion im Bereich der Verbindung von Gehäuseober- und -unterteil.

Auf Wunsch können diese Einheiten aus der Reihe GOF auch für Ölumlaufschmierung geliefert werden, und zwar unter Bezeichnung GUF.

STEHLAGERGEHÄUSE (geteilt)

Reihe GOS 2

mit Ölförderring-Schmierung für Pendelrollenlager
mit zylindrischer Bohrung

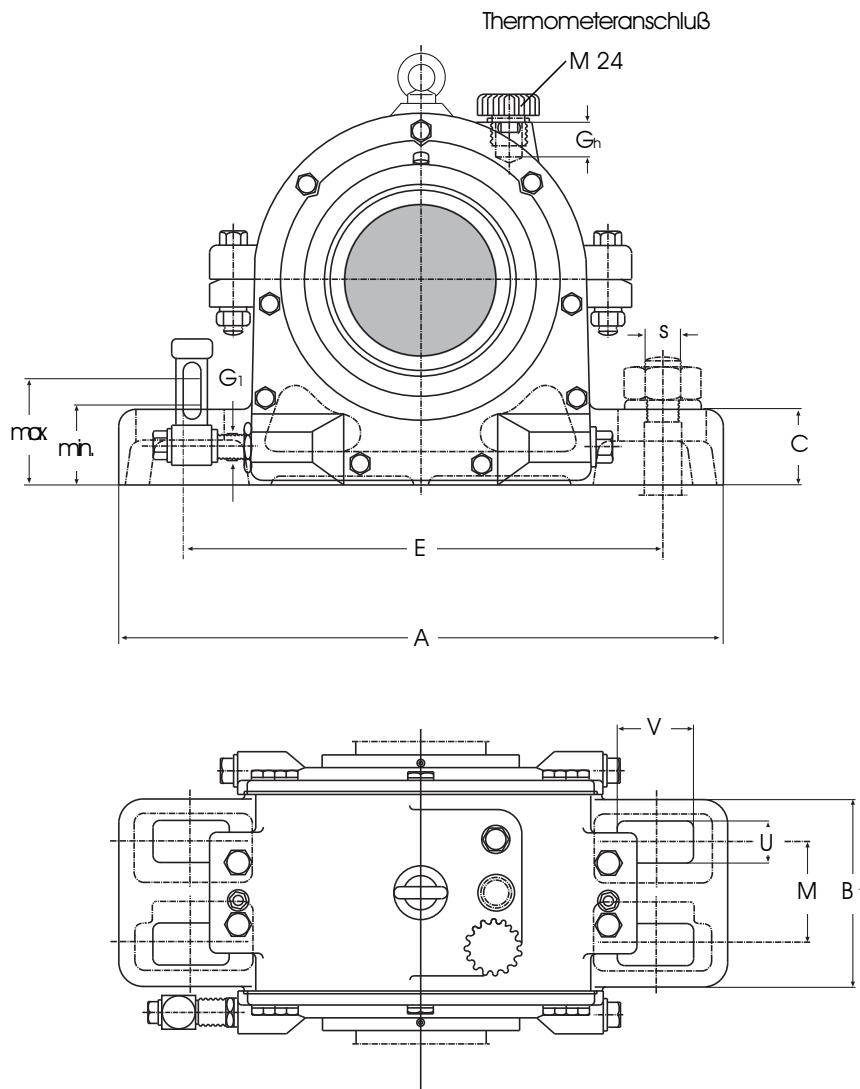

Kurz- zeichen Gehäuse	Welle d	d ₁	d ₂	H ₁	H	A	E	C	S	S ₁	V	U	M	B ₁	B	L	L ₁	L ₂	A ₁	G ₁	G ₂	G _n
mm																						
GOS 217	85	83	96	125	230	330	260	35	M20	5	40	24	60	110	182	180	172,5	90	7,5	R ¹ / ₂	R ³ / ₈	27
GOS 218	90	88	100	135	245	360	290	45	M20	5	40	24	70	120	190	190	180	95	10	R ¹ / ₂	R ³ / ₈	27
GOS 219	95	93	105	140	255	360	290	45	M20	5	40	24	80	120	210	200	192	100	8	R ¹ / ₂	R ³ / ₈	27
GOS 220	100	98	110	145	270	400	320	50	M24	5	45	28	75	130	205	206	196	103	10	R ¹ / ₂	R ¹ / ₂	27
GOS 222	110	108	120	160	290	420	347	50	M24	5	45	28	75	145	216	229	216	114,5	13	R ¹ / ₂	R ¹ / ₂	27
GOS 224	120	118	135	170	315	420	347	55	M24	8	45	28	90	170	245	276	258	138	18	R ¹ / ₂	R ¹ / ₂	27
GOS 226	130	128	145	180	335	450	377	60	M24	8	45	28	100	180	260	270	255	135	15	R ¹ / ₂	R ¹ / ₂	32
GOS 228	140	138	160	190	355	500	415	65	M30	8	45	35	100	190	265	280	265	140	15	R ¹ / ₂	R ³ / ₄	33
GOS 230	150	148	170	200	375	540	450	65	M30	8	50	35	115	190	265	280	265	140	15	R ¹ / ₂	R ³ / ₄	44
GOS 232	160	158	178	215	405	560	470	65	M30	10	50	35	120	205	280	316	298	158	18	R ¹ / ₂	R ³ / ₄	38
GOS 234	170	168	195	235	440	610	515	70	M30	10	55	35	130	230	310	350	330	175	20	R ¹ / ₂	R ³ / ₄	46
GOS 236	180	177	205	245	455	650	545	75	M30	10	65	35	150	240	320	360	340	180	20	R ¹ / ₂	R ³ / ₄	44
GOS 238	190	188	220	260	480	720	590	85	M36	12	70	42	150	250	335	370	350	185	20	R ¹ / ₂	R ³ / ₄	50
GOS 240	200	198	227	275	510	730	600	85	M36	12	70	42	160	260	350	378	358	189	20	R ¹ / ₂	R ³ / ₄	44
GOS 244	220	218	255	305	565	820	670	95	M36	12	70	42	180	280	370	404	384,5	202	19,5	R ¹ / ₂	R ³ / ₄	48
GOS 248	240	238	270	340	625	900	740	100	M36	12	80	42	190	290	380	420	400	210	20	R ¹ / ₂	R ³ / ₄	56

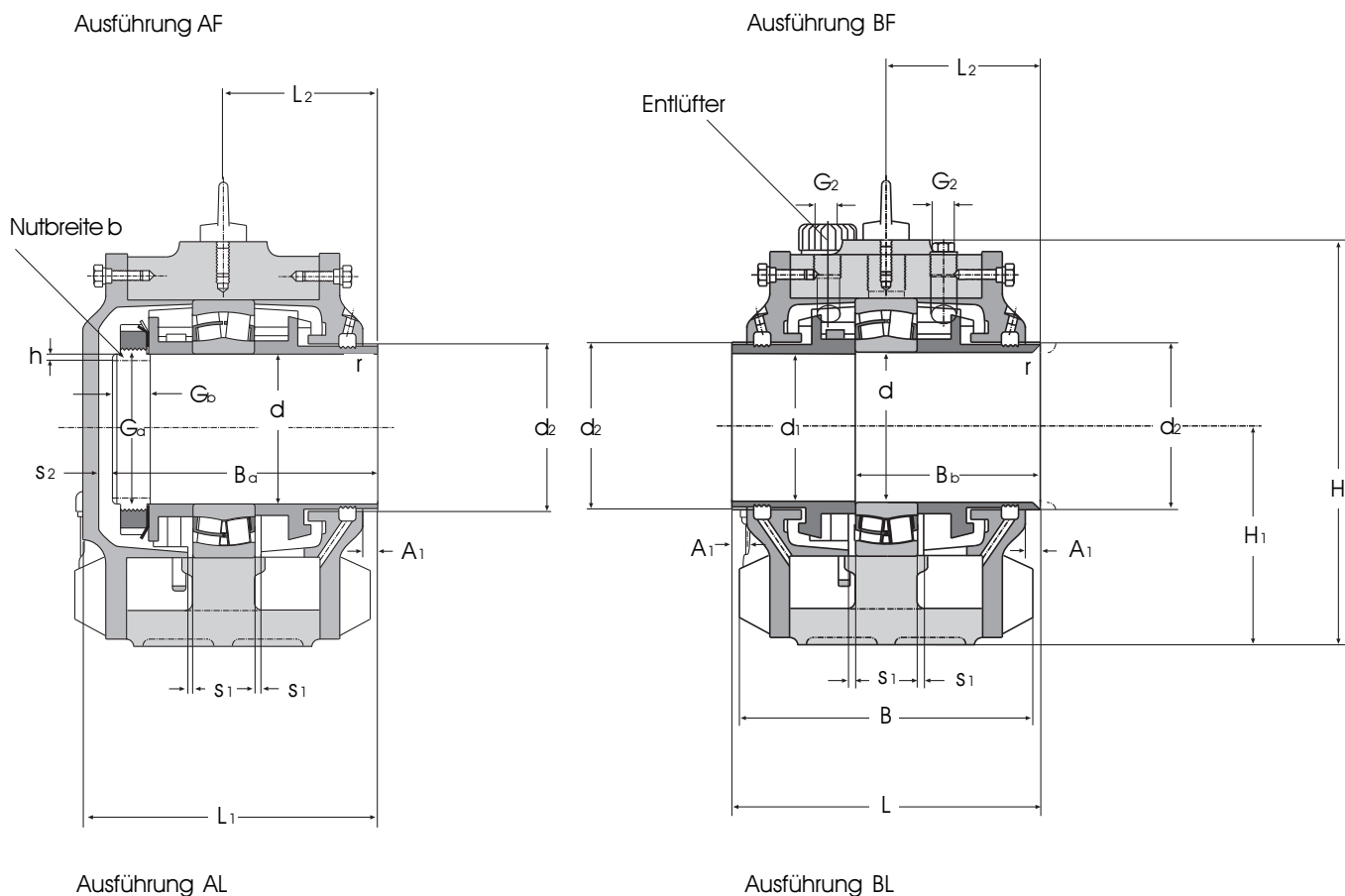

Kurz- zeichen Lager	Anschlussmaße			Gb mm	b	h	r	s2	Öl- menge ltr.	Ölstand		Passende Sicher- wellen- mutter	Sicher- ungs- blech	Gewicht	
	Ba	Bb	Ga							max.	min			A kg	B
22217	150	105	M 85x2	22	11	4	1,6	14,5	0,7	63	42	KM 17	MB 17	22,5	23,5
22218	161	112	M 90x2	23	11	4	1,6	11	0,8	68	45	KM 18	MB 18	35	37
22219	171	118	M 95x2	24	11	4	1,6	11	0,9	70	50	KM 19	MB 19	39	41
22220	177	123	M 100x2	25	13	4	1,6	9	1,0	70	50	KM 20	MB 20	44	46
22222	192	138	M 110x2	26	13	5	1,6	14	1,3	70	50	KM 22	MB 22	54	57
22224	225	164	M 120x2	28	15	6	1,6	23	1,7	80	60	KM 24	MB 24	74	76
22226	226	164	M 130x2	30	15	6	2,5	19	2,3	85	60	KM 26	MB 26	84	89
22228	234	170	M 140x2	30	17	6	2,5	19	2,4	85	60	KM 28	MB 28	107	114
22230	239	173	M 150x2	32	17	6	2,5	16	2,8	90	60	KM 30	MB 30	125	131
22232	266	193	M 160x3	35	19	7	2,5	20	3,3	95	65	KM 32	MB 32	154	162
22234	290	213	M 170x3	37	19	7	3	28	5,0	105	75	KM 34	MB 34	189	197
22236	296	218	M 180x3	38	21	7	5	32	5,2	115	80	KM 36	MB 36	208	217
22238	317	226	M 190x3	39	21	7	6	18	5,8	120	85	KM 38	MB 38	238	249
22240	315	233	M 200x3	40	21	7	6	28	7,0	125	85	KM 40	MB 40	281	294
22244	342	251	Tr 220x4	44	25	8	6	27	8,5	140	95	HM 44T	MB 44	371	392
22248	360	266	Tr 240x4	47	25	8	6	25	9,5	155	110	HM 48T	MB 48	445	475

STEHLAGERGEHÄUSE (geteilt)

Reihe GOS 5

mit Ölförderring-Schmierung für Pendelrollenlager
mit Spannhülse

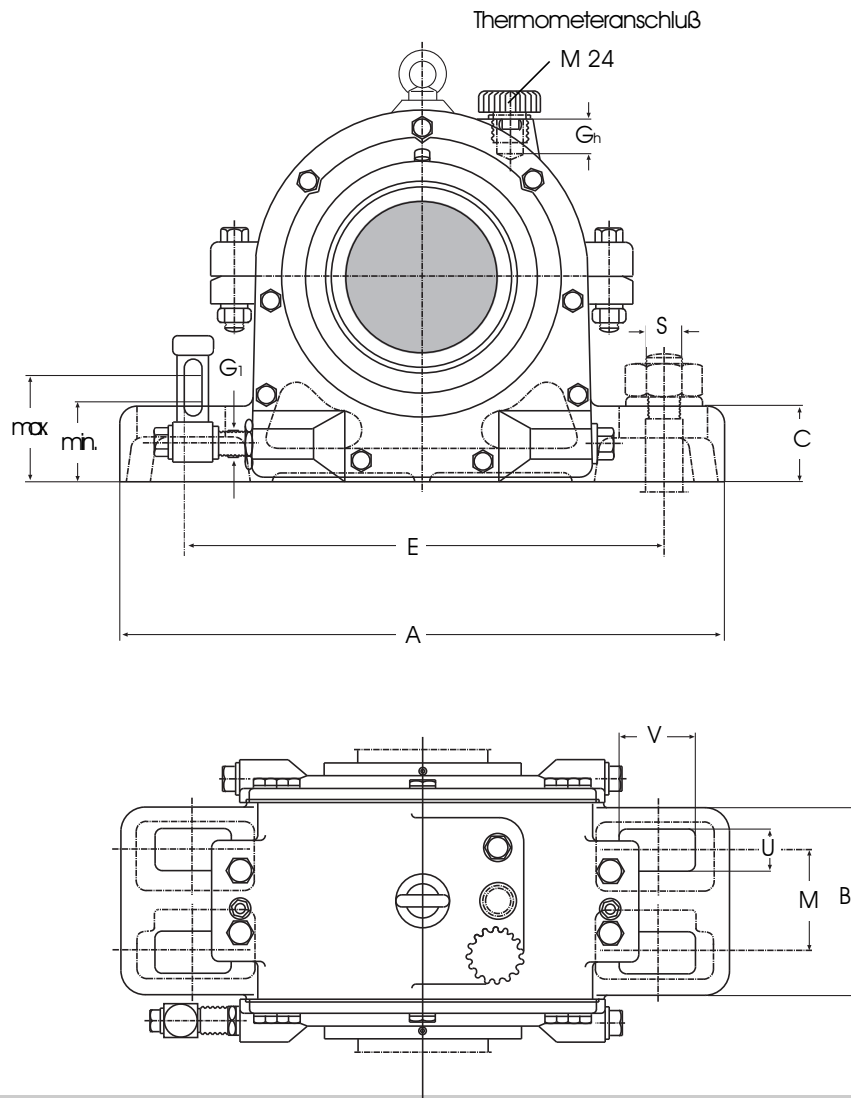

Kurzzeichen Gehäuse	Welle d	d ₂	H ₁	H	A	E	C	S	S ₁	V	U	M	B ₁	B	L	L ₁	L ₂	A ₁	G ₁	G ₂	G ₃
mm																					
GOS 517	75	96	125	230	330	260	35	M20	5	40	24	60	110	182	180	172,5	90	7,5	R ¹ / ₂	R ³ / ₈	27
GOS 518	80	100	135	245	360	290	45	M20	5	40	24	70	120	190	190	180	95	10	R ¹ / ₂	R ³ / ₈	27
GOS 519	85	105	140	255	360	290	40	M20	5	40	24	80	135	210	200	192	100	8	R ¹ / ₂	R ³ / ₈	27
GOS 520	90	110	145	270	400	320	50	M24	5	45	28	75	130	205	206	196	103	10	R ¹ / ₂	R ¹ / ₂	27
GOS 522	100	120	160	290	420	347	50	M24	5	45	28	75	145	216	229	216	114,5	13	R ¹ / ₂	R ¹ / ₂	27
GOS 524	110	135	170	315	420	347	55	M24	8	45	28	90	170	245	276	258	138	18	R ¹ / ₂	R ¹ / ₂	27
GOS 526	115	145	180	335	450	377	60	M24	8	45	28	100	180	260	270	255	135	15	R ¹ / ₂	R ¹ / ₂	32
GOS 528	125	160	190	355	500	415	65	M30	8	45	35	100	190	265	280	265	140	15	R ¹ / ₂	R ³ / ₄	33
GOS 530	135	170	200	375	540	450	65	M30	8	50	35	115	190	265	280	265	140	15	R ¹ / ₂	R ³ / ₄	44
GOS 532	140	178	215	405	560	470	65	M30	10	50	35	120	205	280	316	298	158	18	R ¹ / ₂	R ³ / ₄	38
GOS 534	150	195	235	440	610	515	70	M30	10	55	35	130	230	310	350	330	175	20	R ¹ / ₂	R ³ / ₄	46
GOS 536	160	205	245	455	650	545	75	M30	10	65	35	150	240	320	360	340	180	20	R ¹ / ₂	R ³ / ₄	44
GOS 538	170	220	260	480	720	590	85	M36	12	70	42	150	250	335	370	350	185	20	R ¹ / ₂	R ³ / ₄	50
GOS 540	180	227	275	510	730	600	85	M36	12	70	42	160	260	350	378	358	189	20	R ¹ / ₂	R ³ / ₄	44
GOS 544	200	255	305	565	820	670	95	M36	12	80	42	180	280	370	404	384,5	202	19,5	R ¹ / ₂	R ³ / ₄	48
GOS 548	220	270	340	625	900	740	100	M36	12	80	42	190	290	380	420	400	210	20	R ¹ / ₂	R ³ / ₄	56

STEHLAGERGEHÄUSE (geteilt)

Reihe GOS 5
mit Ölförderring-Schmierung für Pendelrollenlager
mit Spannhülse

Ausführung AF

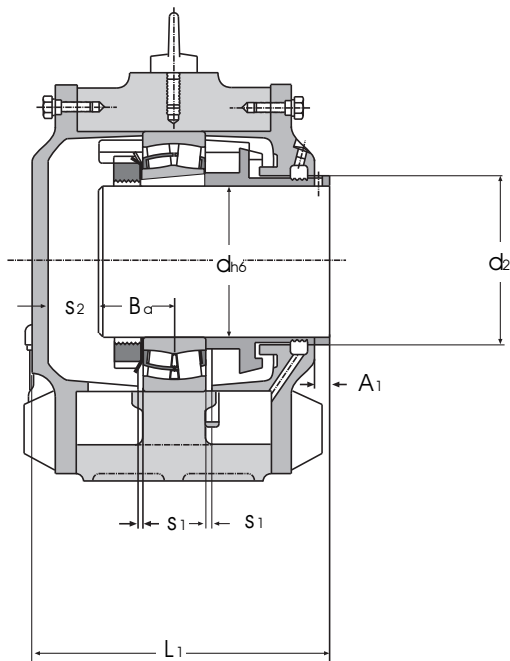

Ausführung BF

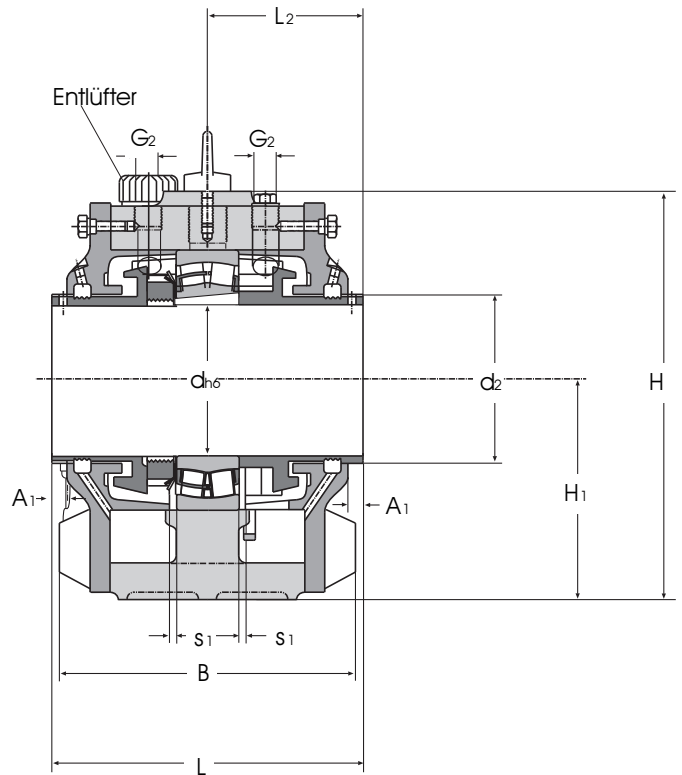

Ausführung AL

Ausführung BL

Kurzzeichen Lager	B _α mm	S ₂ mm	Öl- menge ltr.	Ölstand		Passende Spannhülse	Gewicht Ausführung	
				max. mm	min mm		A	B
22217 K	40	34,5	0,7	63	42	H 317	33	34
22218 K	42	35	0,8	68	45	H 318	38	39
22219 K	44	38	0,9	70	50	H 319	40	42
22220 K	46	37	1,0	70	50	H 320	45	47
22222 K	52	36,5	1,3	77	50	H 322	56	59
22224 K	56	54	1,7	80	60	H 3124	71	75
22226 K	58	52	2,3	85	60	H 3126	88	94
22228 K	63	51	2,4	85	60	H 3128	113	119
22230 K	66	49	2,8	90	60	H 3130	131	137
22232 K	73	55	3,3	95	65	H 3132	159	166
22234 K	77	65	5,0	105	75	H 3134	198	208
22236 K	78	70	5,2	115	80	H 3136	215	225
22238 K	82	68	5,8	120	85	H 3138	244	255
22240 K	86	69	7,0	125	85	H 3140	286	303
22244 K	95	72	8,5	140	95	H 3144	385	403
22248 K	105	70	9,5	155	110	H 3148	455	490

STEHLAGERGEHÄUSE (geteilt)

Reihe GOS 3

mit Ölförderring-Schmierung für Pendelrollenlager
mit zylindrischer Bohrung

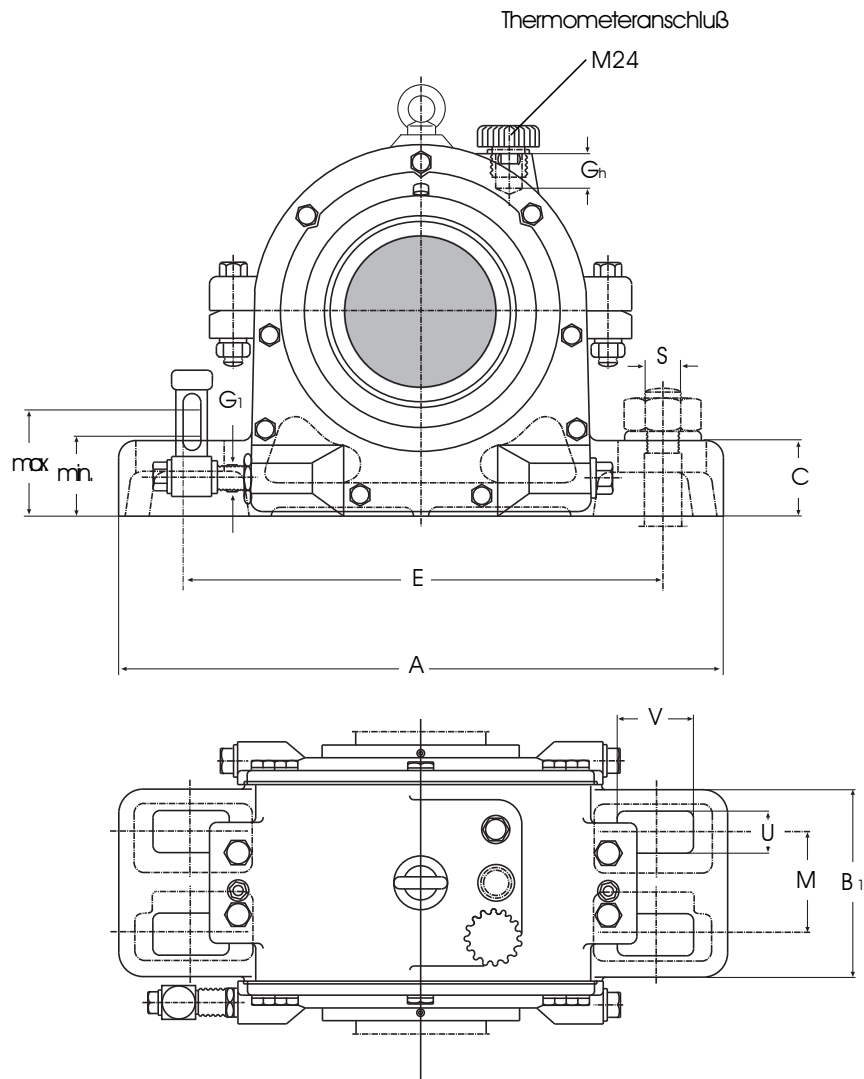

Kurz- zeichen Gehäuse	Welle d	d ₁	d ₂	H _i	H	A	E	C	S	S ₁	V	U	M	B ₁	B	L	L ₁	L ₂	A ₁	G ₁	G ₂	G _n
mm																						
GOS 310	50	49	58	95	168	270	210	30	M16	3	30	19	50	92	145	150	142,5	75	7,5	R ¹ / ₄	R ³ / ₈	27
GOS 311	55	53	65	100	180	290	233	30	M16	3	33	19	50	95	148	155	147,5	77,5	7,5	R ¹ / ₄	R ³ / ₈	27
GOS 312	60	58	70	110	198	290	230	30	M16	5	34	19	55	100	152	170	162,5	85	7,5	R ¹ / ₄	R ³ / ₈	27
GOS 314	70	65	80	125	230	330	260	35	M20	5	40	24	60	110	182	180	172,5	90	7,5	R ¹ / ₂	R ³ / ₈	27
GOS 316	80	78	95	140	255	360	290	40	M20	5	40	24	80	135	210	214	199	107	15	R ¹ / ₂	R ³ / ₈	27
GOS 318	90	88	104	155	280	400	317	50	M24	5	45	28	95	165	246	240	225	120	15	R ¹ / ₂	R ¹ / ₂	32
GOS 320	100	98	115	170	315	420	347	55	M24	8	45	28	90	170	245	270	255	135	15	R ¹ / ₂	R ¹ / ₂	27
GOS 322	110	108	130	190	355	500	415	65	M30	8	45	35	100	190	265	290	270	145	20	R ¹ / ₂	R ³ / ₄	33
GOS 324	120	118	140	200	375	540	450	65	M30	8	50	35	115	190	265	306	285,5	153	20,5	R ¹ / ₂	R ³ / ₄	44
GOS 326	130	128	150	215	405	560	470	65	M30	8	50	35	120	205	285	320	300	160	20	R ¹ / ₂	R ³ / ₄	38
GOS 328	140	138	165	230	425	630	510	80	M30	8	60	35	120	220	300	340	320	170	20	R ¹ / ₂	R ³ / ₄	42
GOS 330	150	148	175	245	455	650	545	75	M30	10	65	35	150	240	320	350	335	175	15	R ¹ / ₂	R ³ / ₄	44
GOS 332	160	158	190	260	480	720	590	85	M36	10	70	42	150	250	335	370	350	185	20	R ¹ / ₂	R ³ / ₄	50
GOS 334	170	168	197	275	510	730	600	85	M36	12	70	42	160	260	350	378	358	189	20	R ¹ / ₂	R ³ / ₄	44
GOS 336	180	178	210	305	565	820	670	95	M36	12	80	42	180	280	370	404	384,5	202	19,5	R ¹ / ₂	R ³ / ₄	48

STEHLAGERGEHÄUSE (geteilt)

Reihe GOS 3

mit Ölförderring-Schmierung für Pendelrollenlager
mit zylindrischer Bohrung

Ausführung AF

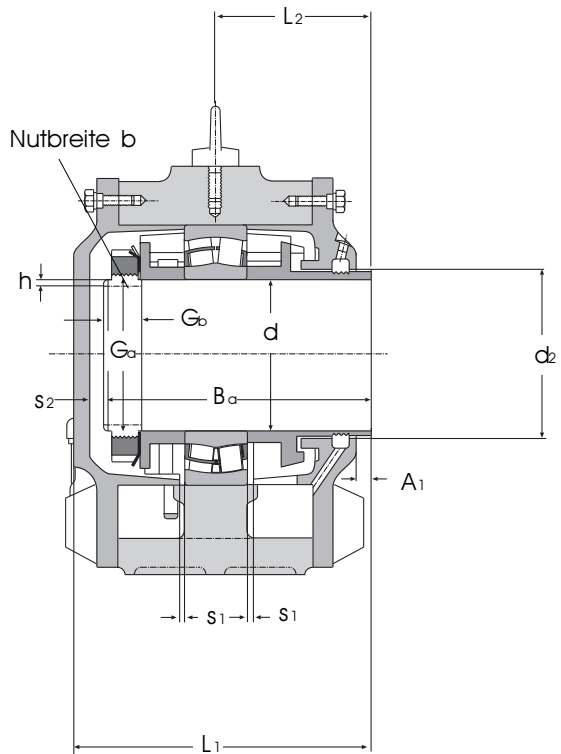

Ausführung BF

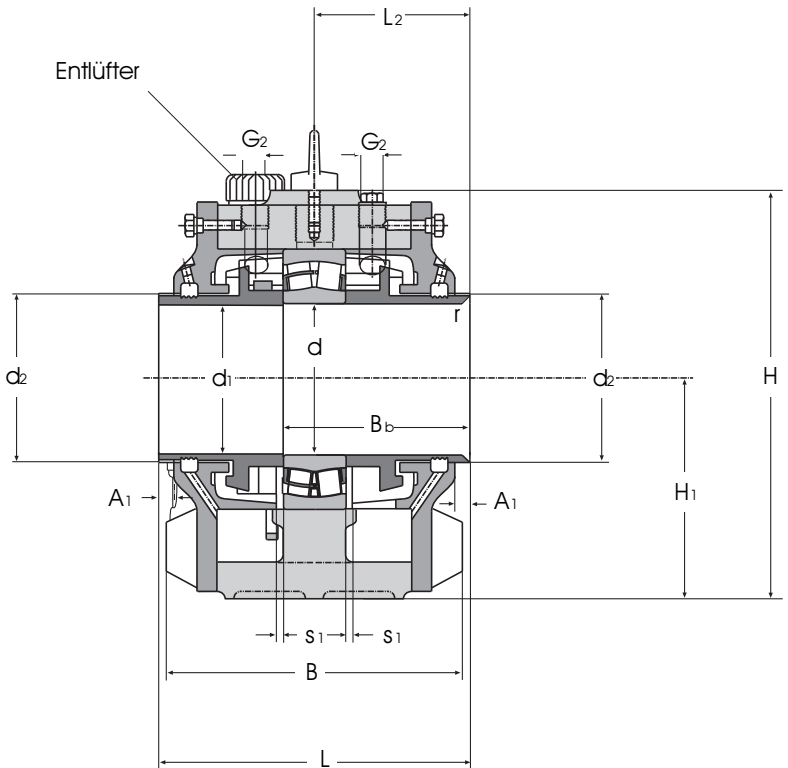

Ausführung AL

Ausführung BL

Kurz- zeichen Lager	Anschlussmaße			Gb mm	b	h	r	s2	Öl- menge ltr.	Ölstand		Passende Wellen- mutter	Sicher- ungs- blech	Gewicht	
	Ba	Bb	Ga							max.	min			A	B
22310	128	92	M50x1,5	18	7	3	1,6	8,5	0,3	53	33	KM 10	MB 10	22	23
22311	134	96	M55x2	17	9	3	1,6	7,5	0,4	53	37	KM 11	MB 11	24	26
22312	147	105	M60x2	17	9	3	1,6	7,5	0,5	60	40	KM 12	MB 12	25	27
22314	156	112	M70x2	18	9	4	1,6	8,5	0,6	65	45	KM 14	MB 14	31	32
22316	181	133	M80x2	22	11	4	1,6	8	1,0	73	45	KM 16	MB 16	39	42
22318	198	148	M90x2	22	11	4	1,6	17	1,4	80	55	KM 18	MB 18	51	53
22320	226	168	M100x2	27	13	4	2,5	19	1,8	85	57	KM 20	MB 20	70	73
22322	243	180	M110x2	28	13	5	2,5	17	2,0	95	67	KM 22	MB 22	105	110
22324	254	192	M120x2	28	15	6	2,5	19	2,8	100	65	KM 24	MB 24	125	127
22326	265	202	M130x2	30	15	6	3	26	3,4	105	70	KM 26	MB 26	152	158
22328	287	215	M140x2	30	17	6	3	21	4,2	115	70	KM 28	MB 28	180	188
22330	292	225	M150x2	33	17	6	6	31	6,0	120	75	KM 30	MB 30	201	211
22332	315	240	M160x3	36	19	7	6	20	6,5	125	80	KM 32	MB 32	230	240
22334	321	244	M170x3	37	19	7	6	22	7,5	130	85	KM 34	MB 34	270	283
22336	342	260	M180x3	38	21	7	6	27	10,5	155	90	KM 36	MB 36	360	380

STEHLAGERGEHÄUSE (geteilt)

Reihe GOS 6

mit Ölförderring-Schmierung für Pendelrollenlager
mit Spannhülse

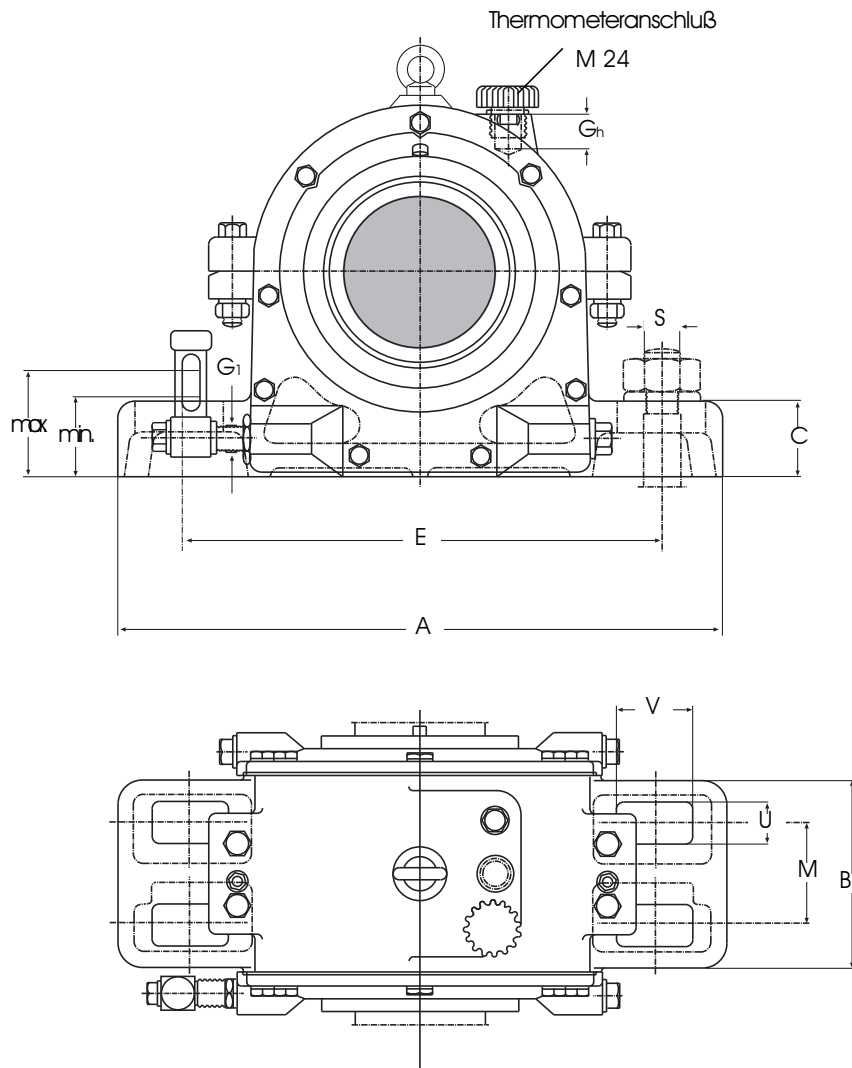

Kurz- zeichen Gehäuse	Welle d	d ₂	H ₁	H	A	E	C	S	S ₁	V	U	M mm	B ₁	B	L	L ₁	L ₂	A ₁	G ₁	G ₂	G ₃
GOS 610	45	58	95	168	270	210	30	M16	3	30	19	50	92	145	150	142,5	75	7,5	R ¹ / ₄	R ³ / ₈	27
GOS 611	50	65	100	180	290	233	30	M16	3	33	19	50	95	148	155	147,5	77,5	7,5	R ¹ / ₄	R ³ / ₈	27
GOS 612	55	70	110	198	290	230	30	M16	5	34	19	55	100	152	170	162,5	85	7,5	R ¹ / ₄	R ³ / ₈	27
GOS 614	60	80	125	230	330	260	35	M20	5	40	24	60	110	182	180	172,5	90	7,5	R ¹ / ₂	R ³ / ₈	27
GOS 616	70	95	140	255	360	290	40	M20	5	40	24	80	135	210	214	199	107	15	R ¹ / ₂	R ³ / ₈	27
GOS 618	80	104	155	280	400	317	50	M24	5	45	28	95	165	246	240	225	120	15	R ¹ / ₂	R ¹ / ₂	32
GOS 620	90	115	170	315	420	347	55	M24	8	45	28	90	170	245	270	255	135	15	R ¹ / ₂	R ¹ / ₂	27
GOS 622	100	130	190	355	500	415	65	M30	8	45	35	100	190	265	290	270	145	20	R ¹ / ₂	R ³ / ₄	33
GOS 624	110	140	200	375	540	450	65	M30	8	50	35	115	190	265	306	285,5	153	20,5	R ¹ / ₂	R ³ / ₄	44
GOS 626	115	150	215	405	560	470	65	M30	8	50	35	120	205	285	320	300	160	20	R ¹ / ₂	R ³ / ₄	38
GOS 628	125	165	230	425	630	510	80	M30	8	60	35	120	220	300	340	320	170	20	R ¹ / ₂	R ³ / ₄	42
GOS 630	135	175	245	455	650	545	75	M30	10	65	35	150	240	320	350	335	175	15	R ¹ / ₂	R ³ / ₄	44
GOS 632	140	190	260	480	720	590	85	M36	10	70	42	150	250	335	370	350	185	20	R ¹ / ₂	R ³ / ₄	50
GOS 634	150	197	275	510	730	600	85	M36	12	70	42	160	260	350	378	358	189	20	R ¹ / ₂	R ³ / ₄	44
GOS 636	160	210	305	565	820	670	95	M36	12	80	42	180	280	370	404	384,5	202	19,5	R ¹ / ₂	R ³ / ₄	48

STEHLAGERGEHÄUSE (geteilt)

Reihe GOS 6
mit Ölförderring-Schmierung für Pendelrollenlager
mit Spannhülse

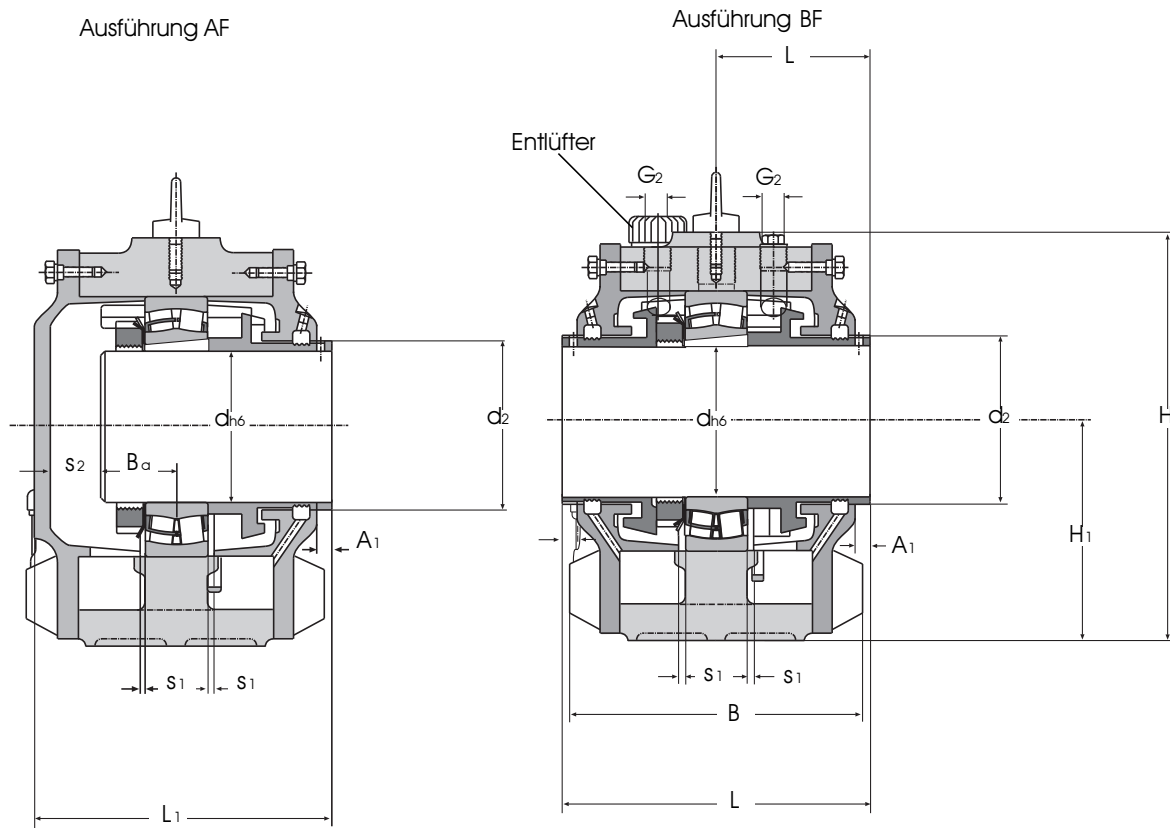

Ausführung AL

Ausführung BL

Kurzzeichen Lager	B _a mm	S ₂ mm	Öl- menge ltr.	Ölstand		Passende Spannhülse	Gewicht Ausführung		
				max mm	min mm		A	kg	B
22310 K	36	25	0,3	53	33	H 2310	23		24
22311 K	37	27	0,4	53	37	H 2311	25		26
22312 K	40	29	0,5	60	40	H 2312	25		26
22314 K	43	31	0,6	65	45	H 2314	32		33
22316 K	50	32	1,0	73	45	H 2316	41		43
22318 K	54	41	1,4	80	55	H 2318	52		55
22320 K	62	48	1,8	85	57	H 2320	71		74
22322 K	66	49	2,0	95	67	H 2322	107		112
22324 K	70	50	2,8	100	65	H 2324	124		130
22326 K	75	53	3,4	105	70	H 2326	155		163
22328 K	80	58	4,2	115	70	H 2328	183		190
22330 K	85	63	6,0	120	75	H 2330	207		215
22332 K	90	60	6,5	125	80	H 2332	237		246
22334 K	94	60	7,5	130	85	H 2334	280		293
22336 K	98	69	10,5	155	90	H 2336	375		390